

Milton Roy Metering Pump Technology

Meets API 675 Requirements

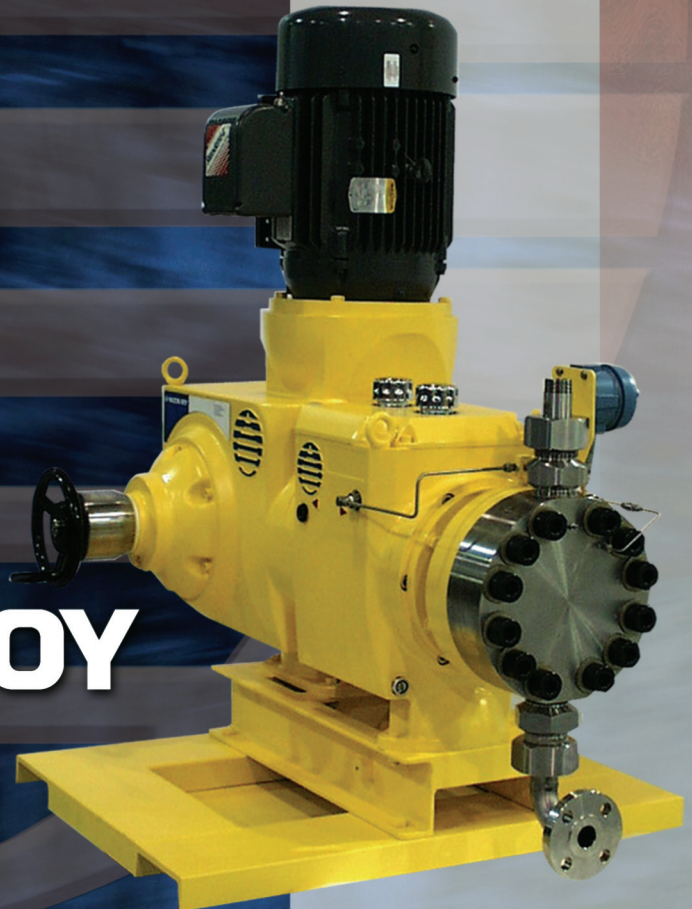
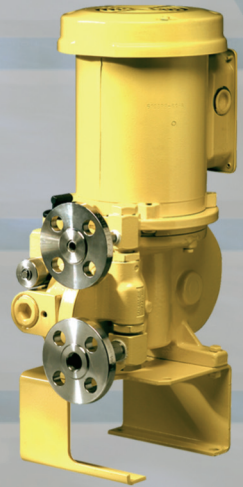

MILTON ROY

Metering Pump Technology

Bulletin 210

The Metering Pump	1
Metering Pump Basic Components	1
Metering Pump Characteristics	2
Capacity and Pressure Capabilities Chart	3
Liquid End Designs	4
Packed Plunger	4
Disc Diaphragm	5
Mechanically Actuated Diaphragm	6
Metallic Diaphragm and Critical Service Head	7
High Performance Diaphragm - Advanced Liquid End Design	8
Metering Pump Drive Mechanisms	10
Hydraulic Bypass	10
Polar Crank	11
CENTRAC	12
Capacity Adjustment	14
Modifications	15
Metering Pump System Components	16
Other Milton Roy Products	18



MILTON ROY

The Metering Pump

The metering pump is a positive displacement chemical dosing device with the ability to vary capacity manually or automatically as process conditions require. It features a high level of repetitive accuracy and is capable of pumping a wide range of chemicals including acids, bases, corrosives or viscous liquids and slurries.

The pumping action is developed by a reciprocating piston which is either in direct contact with the process fluid, or is shielded from the fluid by a diaphragm. Diaphragms are actuated by hydraulic fluid between the piston and the diaphragm.

Metering pumps are generally used in applications where one or more of the following conditions exist.

- Low flow rates in ml/hr or GPH are required
- High accuracy feed rate is demanded
- Corrosive, hazardous, or high temperature fluids are handled
- High system pressure exists
- Dosing is controlled by computer, microprocessor, DCS, PLC, or flow proportioning
- Viscous fluids or slurries need to be pumped

Metering Pump Basic Components

Driver:

The pump is usually driven by an AC constant speed motor. Variable speed, pneumatic, and hydraulic drivers are also utilized.

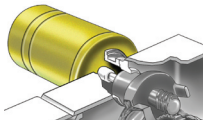

Driver Mechanism:

The drive mechanism translates the rotary motion of the driver into reciprocating movement. Industrial duty pumps will submerge this portion of the pump in an oil bath to assure reliability during continuous operation.

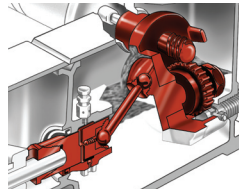

Flow Adjustment:

Pump flow rate is adjustable by varying stroke length, effective stroke length, or stroking speed. Most metering pumps are supplied with a micrometer screw adjustment similar to the one shown here. The micrometer can also be replaced by an electronic or pneumatic actuator to adjust pump flow rate in response to process signal.

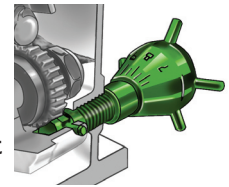

Liquid End:

The liquid end design and materials of construction are determined by the service conditions, and the nature of the fluid to be handled. Temperature, flow rate, fluid viscosity, corrosiveness and other factors are considered.

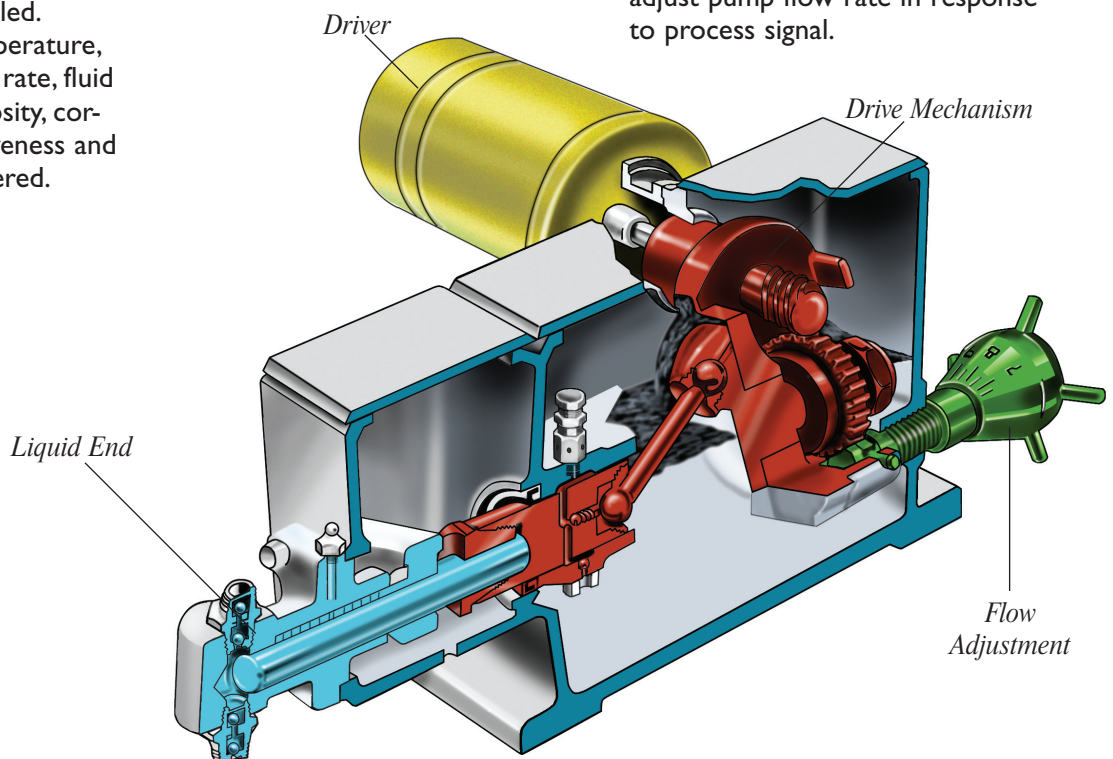
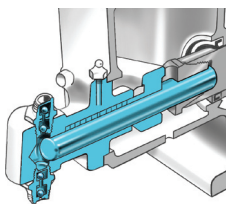

Metering Pump Characteristics

1. The pumping action is developed by a reciprocating piston. This reciprocating motion develops a flow easily represented by a sine wave. Actual flow rate is determined by the following formula:

$$\text{Flow rate} = \text{Displacement} \times \text{Cycles per unit of time.}$$

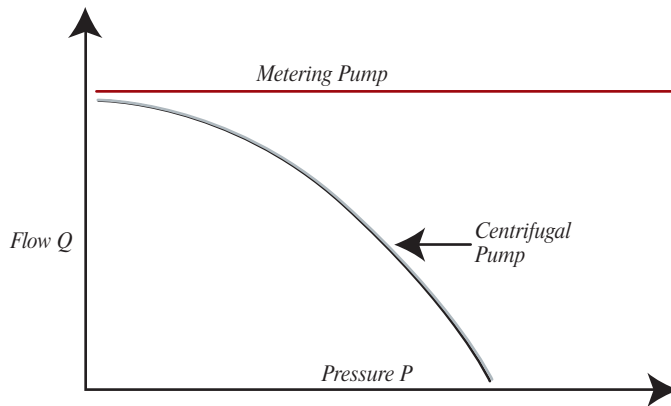
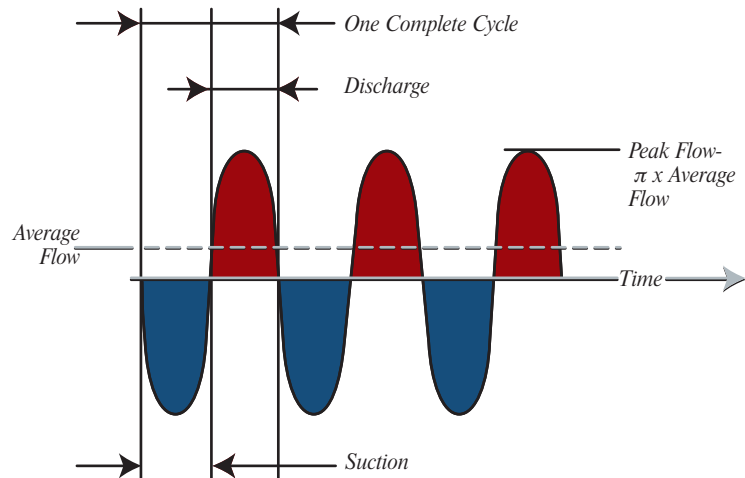

2. Unlike centrifugal pumps, flow rate is not greatly affected by changes in discharge pressure.

3. The metering pump flow vs. stroke characteristic curve is linear. It is not, however, necessarily proportional in that 50% stroke setting may not equal 50% flow. This is due to the fact that the calibration line may not pass through 0 on both axes simultaneously. By measuring flow at 2 stroke settings, plotting both points and drawing a straight line through them, other flow rates vs. stroke can be accurately predicted. The steady state accuracy of a correctly installed industrial grade metering pump is generally $\pm 1.0\%$ or better. Although a metering pump can generally be adjusted to pump at any flow rate between 0 and its maximum capacity, its accuracy is measured over a range determined by the pump's turndown ratio. Most metering pumps have a turndown ratio of 10:1, which simply means that the pump is within its accuracy rating anywhere between 10% and 100% of capacity. Centrac is an example of a new generation metering pump that features higher accuracy, and a greater turndown ratio of 100:1. Therefore, this design will accurately dose anywhere between 1% and 100% of capacity.

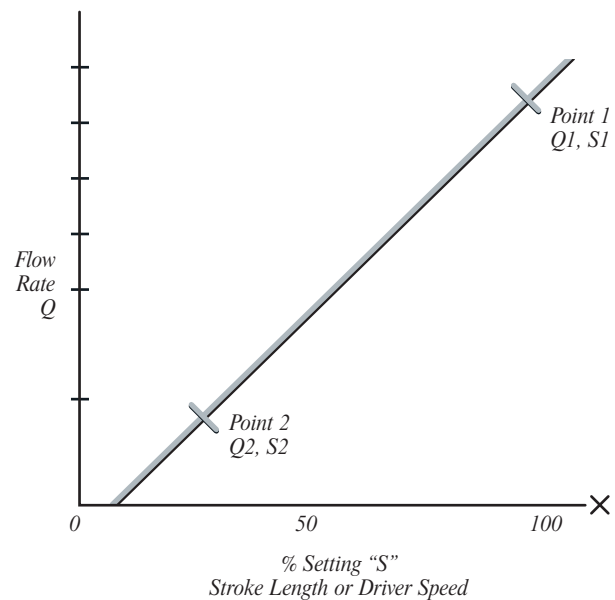

Capacity and Pressure Capabilities

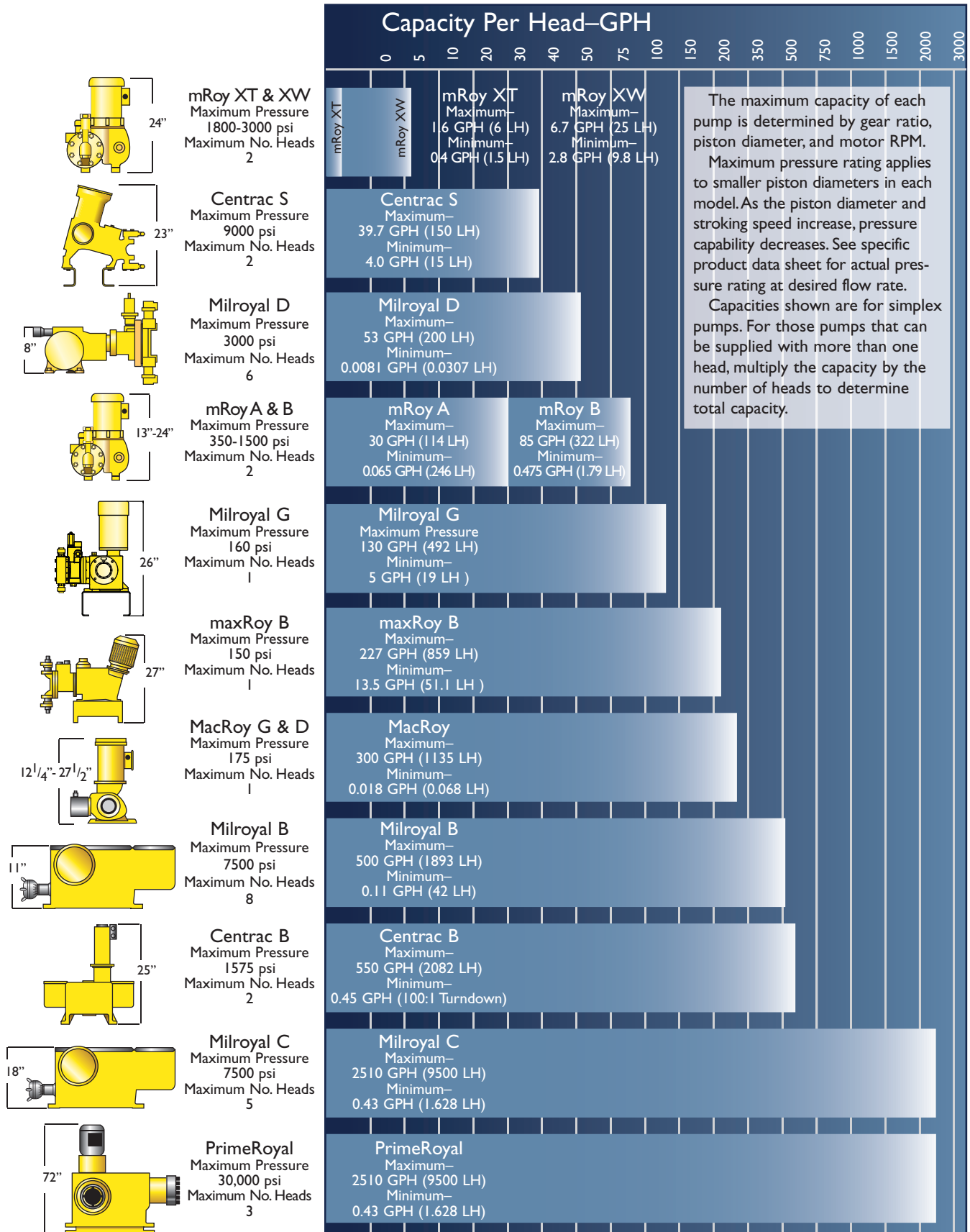

Liquid End Designs

The liquid end, which is referred to as the wetted part of the pump, is selected to meet the specific service conditions of the application. Required flow and pressure ratings are considered, as well as the physical and chemical properties of the liquid. The liquid end's ability to protect the environment is also a major consideration when dealing with toxic or hazardous chemicals.

All liquid ends have several fea-

tures in common. First, the liquid is drawn into the wetted end by the rearward motion of a piston, and expelled by the forward motion. To achieve this, the metering pump is supplied with check valves at the suction and discharge connection points. The check valves contain and release the chemical based on system conditions and gravity.

During the suction portion of the stroke, the motion of the piston lifts

the suction ball check from its seat allowing liquid into the pump. At the same time, the piston's motion and system back pressure hold the upper check valve (discharge) closed. This is then reversed during the discharge stroke.

Check valves are available in several different designs and configurations. The choice of ball or poppet style is determined by Milton Roy's Engineering department based on capacity of the specific pump.

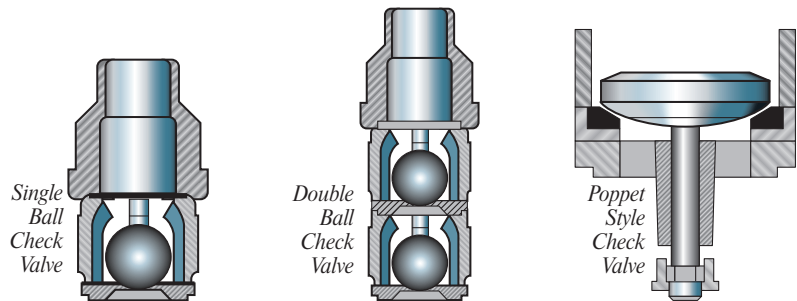
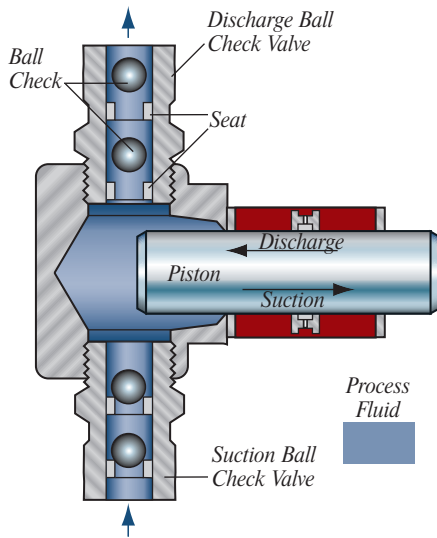

Most pumps feature either single or double ball configuration as standard. The user can also select single or double ball when the application is better served by one or the other. For example, slurries or liquids with large fibers or particles can cause a single ball to leak if particles are trapped between the ball and seat. Therefore, a double ball check offers more stability and accuracy. On the other hand, since each check valve causes some resistance in the flow path even when open, viscous fluids are better handled with a single ball suction check valve.

Packed Plunger

The packed plunger style liquid end is the only liquid end in which the piston is in direct contact with the process fluid. This direct contact offers a number of advantages, including: high suction and discharge pressure capabilities; high temperature resistance, and lowest NPSH requirements.

The reciprocating piston requires packing to seal the wetted parts from the atmosphere. This simple design is effective, but places limitations on the use of packed plunger pumps in certain applications.

Because a small amount of controlled leakage past the packing must be expected, this style liquid end should not be used with hazardous or toxic chemicals. Additionally, the friction between the piston and the packing results in wear that increases leakage. Periodic packing adjustment is necessary to maintain volumetric efficiency. To avoid problems associated with leakage, consider a diaphragm style liquid end.

The packed plunger can handle pressures up to 15,000 psi, and temperatures to 600°F (with special modifications).

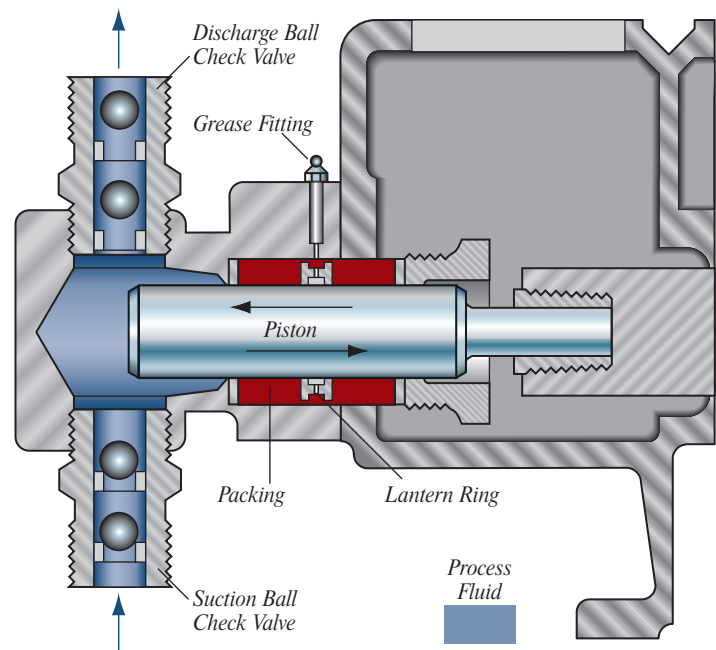

Available on: Milroyal B, Milroyal C, Milroyal D, Centrac, and Maxroyal.

Standard Materials of Construction: 316 SS, Alloy 20, Cast Steel (larger models)

Disc Diaphragm

The disc diaphragm liquid end has a Teflon® diaphragm which acts as a barrier between the piston and the process fluid. The piston's pumping motion is applied to hydraulic fluid which causes the diaphragm to flex back and forth as the piston reciprocates.

The hydraulically actuated diaphragm operates with equal pressure between the hydraulic and process fluids. This eliminates diaphragm stress, since the pressure is essentially equal on both sides at all times. Two contour plates encase the diaphragm to contain its travel.

The hydraulic and process fluids pass through carefully engineered holes in the contour plates in order to come into contact with the diaphragm. Relief and refill valves control the volume of hydraulic fluid. An automatic air bleed valve continuously purges air from the hydraulic fluid.

The diaphragm style pump is sealed. It therefore is an excellent choice for hazardous, toxic, or corrosive chemicals. For extra protection, double diaphragm and leak detection modifications are available, although they are consid-

ered redundant since this design is extremely durable.

Because the process fluid must pass through relatively small holes in the contour plate, the disc diaphragm liquid end is not the best choice for slurries. With the exception of the mRoy P design, disc diaphragms are usually not the best choice when pumping viscous fluids.

The disc diaphragm is capable of handling fluids where the required injection pressure is 3500psi or greater and the fluid temperature exceeds 250°F.

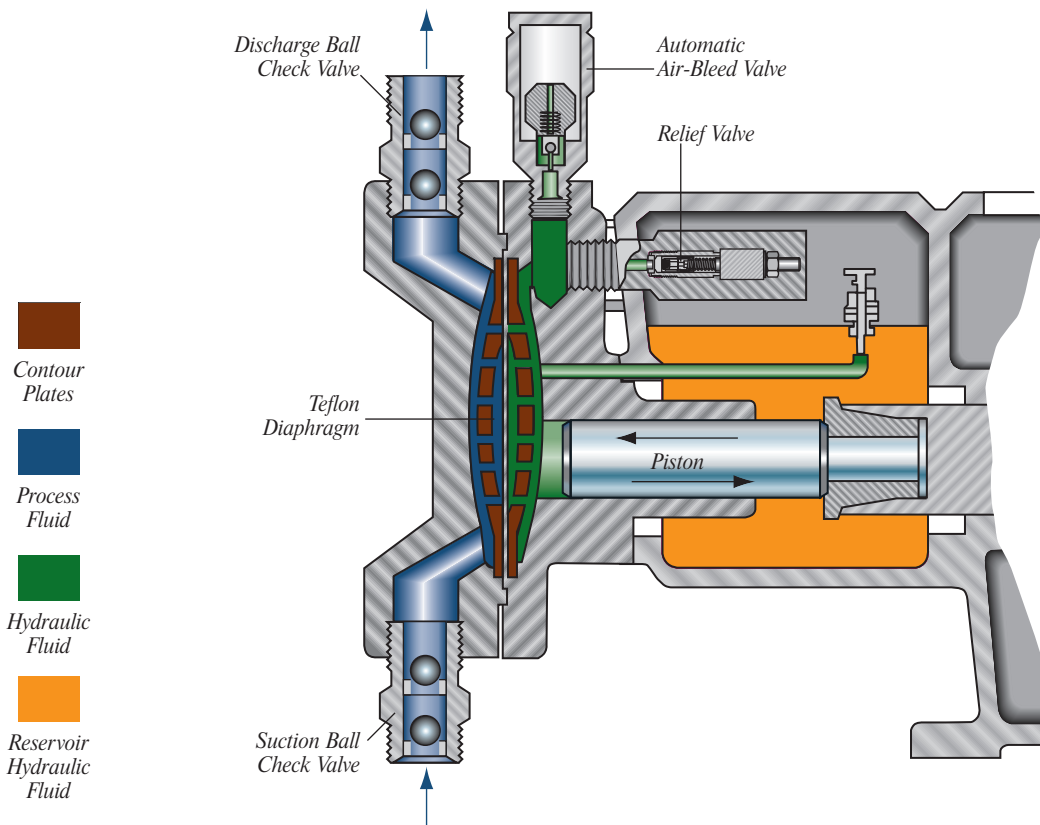

Available on: mRoy A, mRoy B, Milroyal B, Milroyal C
Standard Materials of Construction: 316 SS, Alloy 20, Plastic

Liquid End Designs

Mechanically Actuated Diaphragm Design

The Milton Roy Family of mechanically-actuated diaphragm pump is called the MacRoy Series G. They represent the best balance between low pump cost and high quality performance. Because it has zero diaphragm leakage, it makes a great pump for critical and otherwise expensive chemicals or where environmental issues are involved. The mechanically-actuated series is an excellent choice where slurries and abrasive chemicals are required up to the pump's maximum flow and pressure ranges. They are also well tolerant of high viscosity liquids providing an economical solution for a variety of difficult applications.

Mechanically-actuated pumps operate with a plunger directly attached to the diaphragm. This attachment generally takes place from a bolt and clamp being placed through the plunger and through the diaphragm. The direct attachment of the piston to the diaphragm connects the pump's drive and motor to the liquid end. The motion of the pump drive moves the plunger back and forth, thereby causing suction from the supply tank and pumping the fluid of choice through the attached conveyance infrastructure. This series of pumps generally find pressure peaks at 175 PSI, but

are only limited to flow as a matter of wetted end volume. Maximum life of the pump can be achieved by replacing the diaphragm at the recommended service interval. Leak detection can be easily found from the air-filled chamber residing generally at atmospheric pressure on the drive side of the liquid end. This provides the least expensive leak detection option in the marketplace.

As with any chemical where gas binding can be a problem, it is recommended that a degassing valve be used to release off-gases from the agitation or pressure changes

experienced by a liquid having off-gas characteristics. Some of these liquids that can generate off-gases as a result of pressure losses are NaOCl, H₂O₂, and some specialty chemicals. Mechanically-actuated pumps work well in these applications providing 10:1 turndown as a standard across the product line. The addition of VFD technology and remote stroke control will bring the turndown as high as 100:1.

Mechanically-actuated diaphragm pumps are easily maintained and provide years of service for little effort.

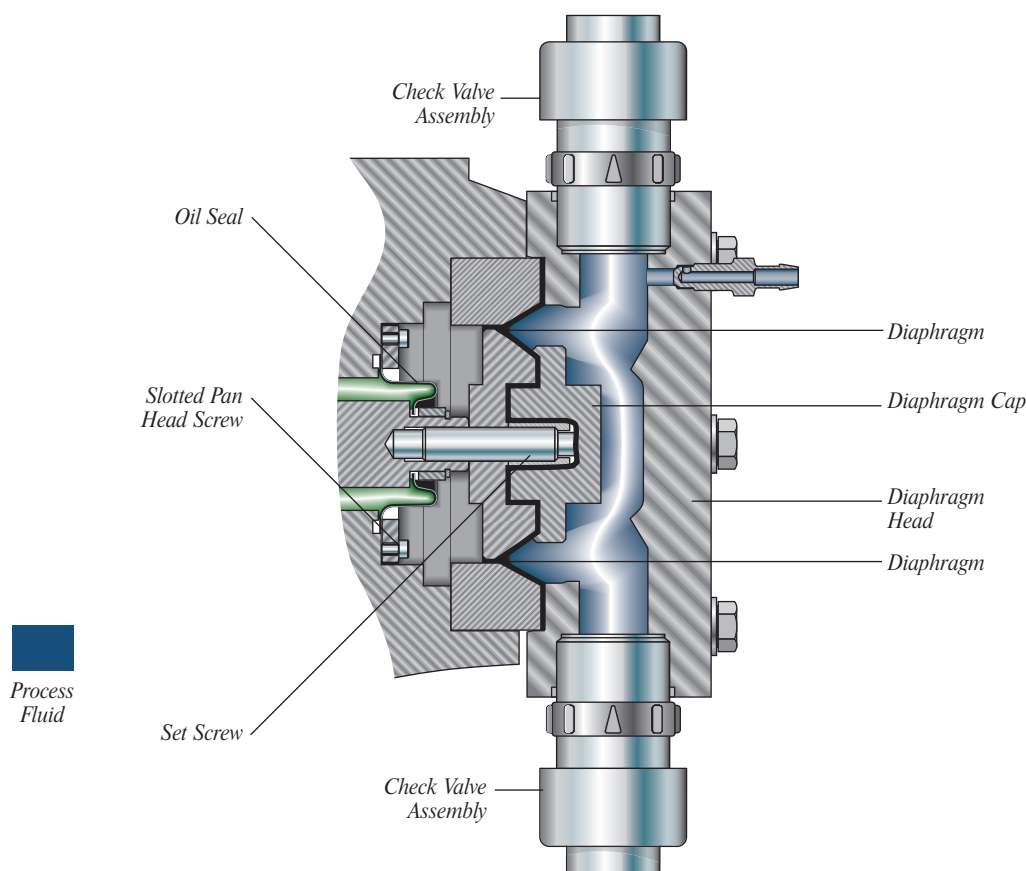

Available on: MacRoy, Standard Materials of Construction: 316 SS, Alloy 20, Plastic

Metallic Diaphragm Liquid End and Critical Service Head

The Milton Roy Series of Metallic Diaphragms are unparalleled for use in critical, high pressure applications such as oil and gas platforms and specialty industrial applications. They are especially useful where temperatures and pressures of both the environment and the process chemical can be variable or otherwise difficult. The Metallic diaphragm lines are preferred for their longevity and durability in many difficult applications.

Metallic diaphragm metering pumps are hydraulically-actuated in the same manner and style as a standard hydraulically-actuated drive liquid end. However, the teflon or other usual diaphragm material is replaced with a special metal alloy particular to the application to produce higher pressures than more

traditional materials. The metal design of the diaphragm also manages difficult chemicals such as abrasives, slurries and other special requirements compounds easier and more efficiently than its more standard version.

Many oil and gas offshore drilling platforms require metallic

diaphragms because of their high reliability and longevity. In any application where critical service is required, the Milton Roy Metallic Diaphragm is the product of choice for these chemical dosing situations.

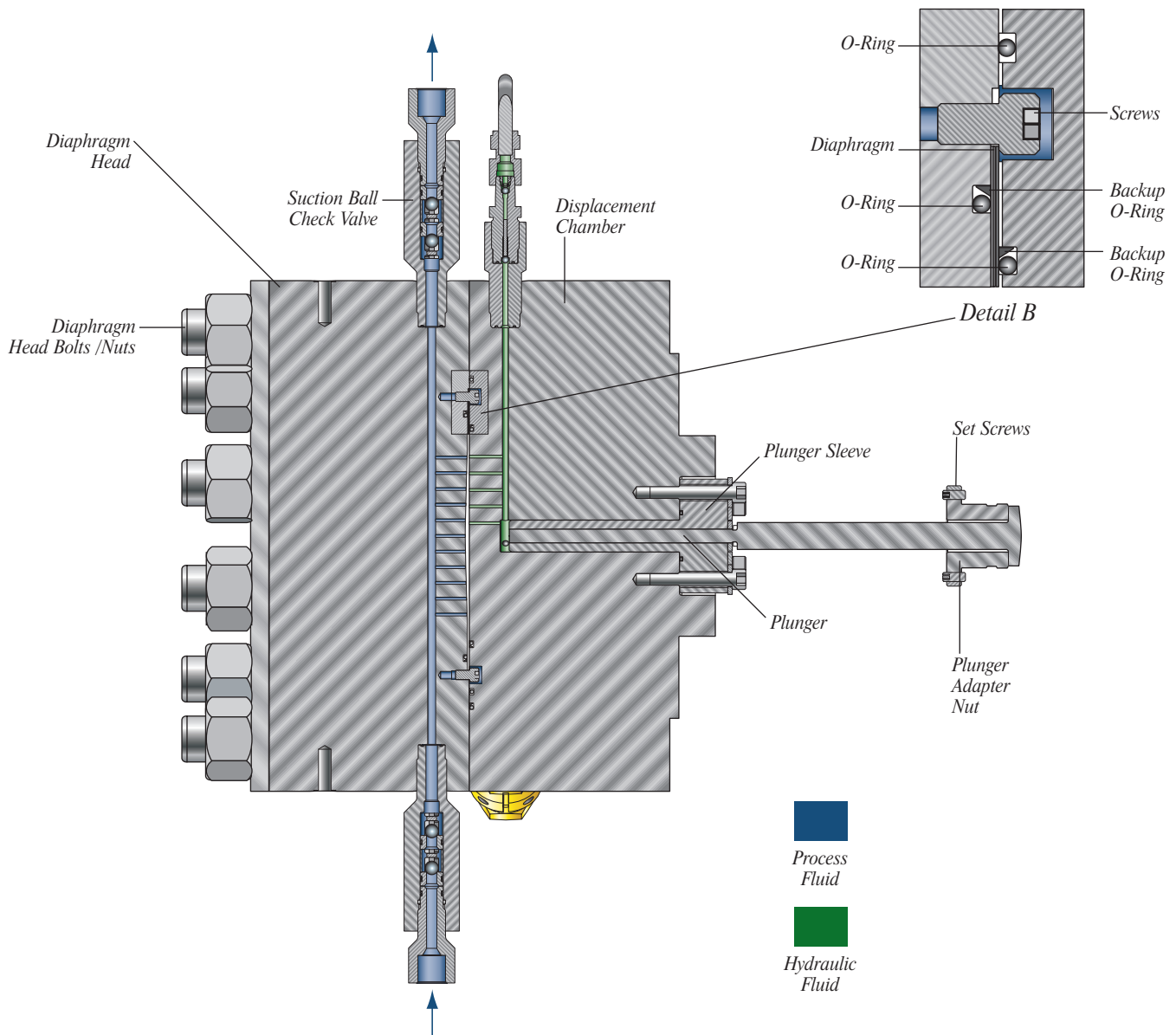

Available on: Milroyal C and PrimeRoyal: 316 SS, Alloy 20, Plastic

High Performance Diaphragm...

The High Performance Diaphragm liquid end, HPD, combines all of the best characteristics of traditional liquid ends into one technologically advanced design. Its operating characteristics and simplicity of operation make it the best pump to consider first for most metering pump applications.

HPD operation is similar to the disc diaphragm in that it is hydraulically actuated and utilizes the same shape and diaphragm. It is similar to a tubular diaphragm in the respect that the process fluid has a "straight through" path through the liquid end. Its low NPSH requirements are similar to that of a packed plunger liquid end. But the primary advantages of the HPD are the unique design features that separate it from traditional designs.

The MARS Advantage

A hydraulically actuated diaphragm liquid end design requires a refill system to compensate for hydraulic fluid that bleeds past the piston or through an air bleed valve during normal operation. Hydraulic fluid is also expelled from the chamber through the internal relief valve when the system experiences excess pressure, and therefore must also be replenished.

The HPD features a Mechanically Actuated Refill System (MARS) that offers a number of advantages over traditional refill systems. To understand the advantages of MARS, traditional refill systems must first be explored.

Traditional Designs

Traditional designs use a system that refills the chamber when a vacuum is created by the inability of the diaphragm to move beyond the hydraulic contour plate. It also refills when the suction is momentarily or permanently starved by accidental valve closure, insufficient NPSH, or other similar occurrences. When this happens, the hydraulic fluid chamber is overfilled because a vacuum has been created even though the diaphragm has not been able to travel rearward. To avoid diaphragm rupture due to overfilled hydraulic oil, a process side contour plate stops the diaphragm's forward travel, and forces the hydraulic relief valve to open, thus expelling the excess fluid.

The contour plate is a concave (actually, concavo-convex) disc that supports the diaphragm and limits its travel. The plate has a series of holes bored through it to permit the fluid

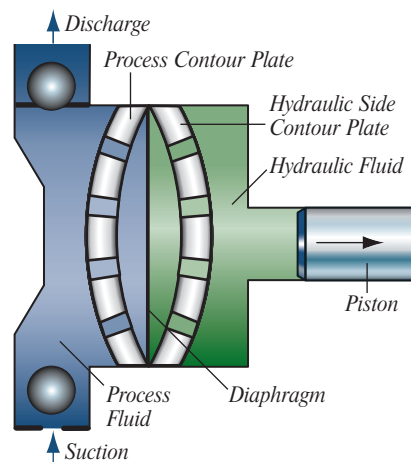

Traditional Liquid End with Process and Hydraulic contour Plates (refill system not shown)

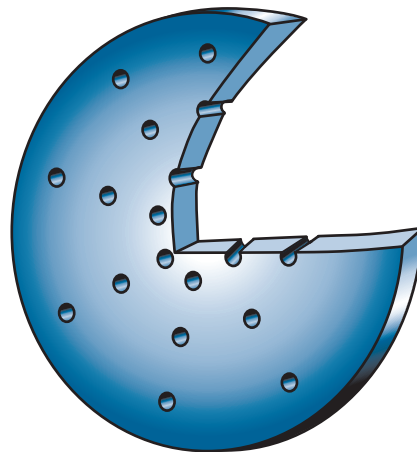

Typical Contour Plate (Section cutaway)

to come into contact with the diaphragm. The pattern and size of these holes requires careful engineering to maintain the contour plate strength required to withstand the force of the diaphragm experienced at operating pressure.

The hydraulic contour plate does not cause any problems in pump operation since the hydraulic fluid passes easily through the contour plate holes. However, a process con-

tour plate, required by traditional disc diaphragm liquid ends, places limitations on the types of process fluids the pump can handle (such as slurries) since the process fluid must also pass through contour plate holes. The process contour plate also creates a pressure loss which raises the NPSH requirement of the liquid end.

The MARS System

The MARS System eliminates the need for a process contour plate by assuring that the hydraulic fluid can only be refilled when the diaphragm has traveled all the way back to the hydraulic contour plate. The diaphragm presses against the MARS valve, which only then permits a poppet valve to open from the vacuum created by insufficient hydraulic fluid. (See the illustration lower right)

Hydraulic overfill is therefore impossible. With the process contour plate gone, the straight through path of the process liquid makes the HPD a perfect choice for slurries and viscous materials. It also lowers the NPSH requirements of the pump, since pressure loss through a process contour plate is eliminated.

The MARS system also simplifies HPD start-up. Unlike other hydraulic liquid ends, the refill valve does not need adjustment. Additionally, since the HPD hydraulic fluid cannot be overfilled, there is no need to perform delicate procedures to synchronize hydraulic fluid balances (a difficult task required for tubular and other double diaphragm liquid ends). With the HPD, you just fill the reservoirs, and turn it on.

...Advanced Liquid End Technology

HPD Preshaped Composite Diaphragm

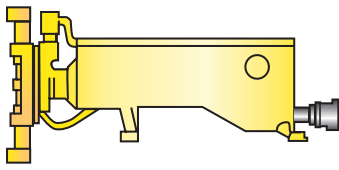

Full side view of HPD Liquid End on MilRoyal Drive

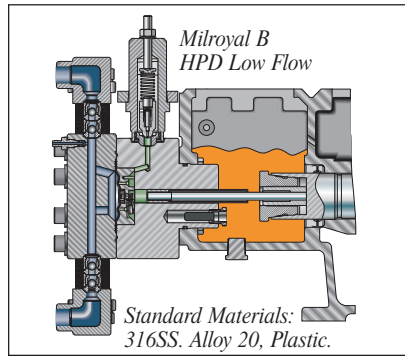

Milroyal B HPD Low Flow

Standard Materials: 316SS, Alloy 20, Plastic.

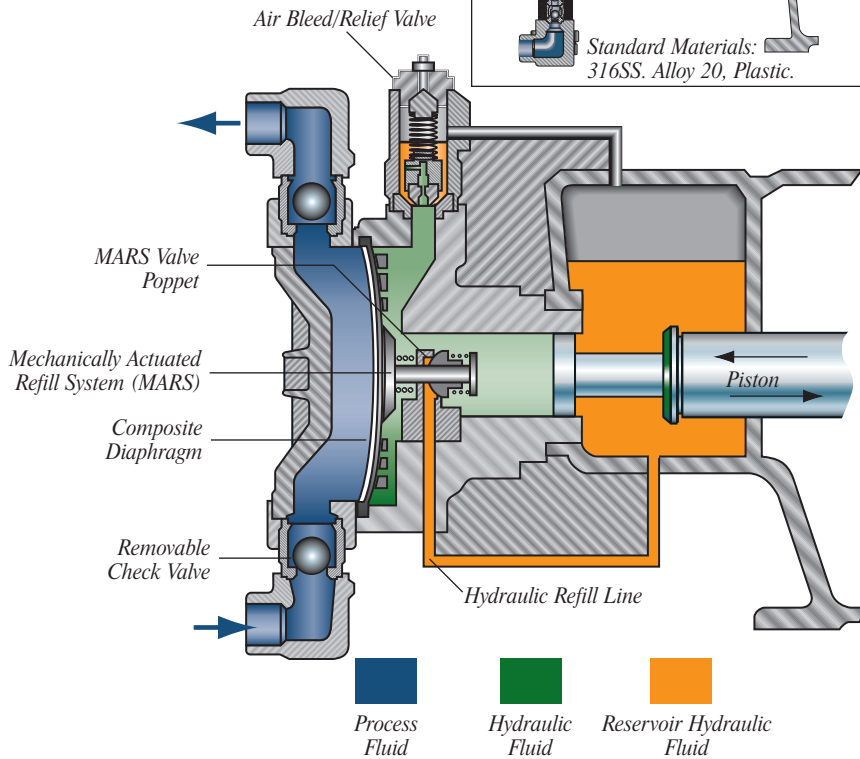

The HPD features a pre-shaped PTFE/elastomer composite disc diaphragm. On the process side, the chemical resistance of PTFE is utilized. On the hydraulic side, the elastomer imparts favorable elastic and mechanical factors.

The composite diaphragm eliminates the inherent problems of pure PTFE diaphragms. PTFE tends to cold flow when compressed between two metal parts (such as those required to seal the hydraulic side from the process side). The HPD composite diaphragm features an integral "O" ring seal around the perimeter of the diaphragm, which provides a better seal between hydraulic and process fluids than conventional diaphragm materials.

The HPD is capable of handling pressures up to 3025 psi and temperatures up to 300°F (with special modifications).

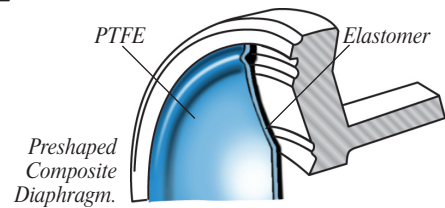

Available on: Milroyal B, Milroyal C, Milroyal D, Centrac and Maxroyal.
Standard Materials of Construction: 316SS, Alloy 20, Plastic.

MARS System Operation

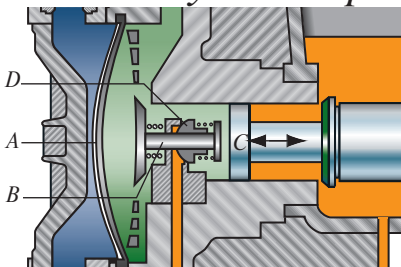

Figure 1
Diaphragm (A) and piston (C) are full forward. Mars valve (B) in forward position holds poppet valve (D) closed, preventing refill line hydraulic oil from entering the chamber.

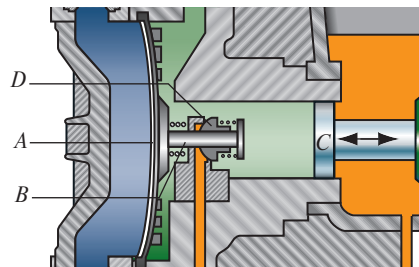

Figure 2
Diaphragm (A) and piston (C) are full rearward. Mars valve (B) is also rearward due to diaphragm position, thus freeing poppet (D) to open if required. Poppet (D) is shown closed, indicating hydraulic oil refill is not required.

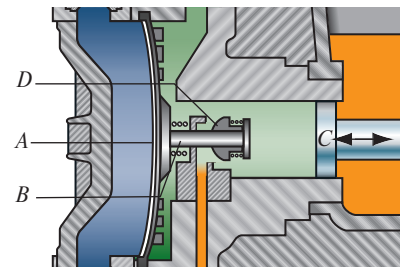

Figure 3
Diaphragm (A) and piston (C) are full rearward, once again forcing Mars valve (B) to its rearward position, which allows poppet (D) to open if required. Low oil volume creates a vacuum and opens poppet, permitting hydraulic fluid to enter the chamber from the refill line.

Metering Pump Drive Mechanisms

All Milton Roy drive mechanisms feature gears that are submerged in an oil bath to assure long life. Capacity can be adjusted while the pump is running or stopped, $\pm 1.0\%$ accuracy over a 10:1 turn-down ratio.

Hydraulic By-Pass

The hydraulic by-pass mechanism features a piston with a constant stroke length that pumps hydraulic fluid, thus transferring the pumping motion to a diaphragm. Therefore, this type of drive can only mate with a hydraulically actuated diaphragm liquid end.

Capacity is varied by changing the location of a hydraulic by-pass port over the piston's path of travel. If the port is positioned at 50% of the piston's stroke length, hydraulic fluid will be relieved through the port during the first half of the piston's stroke, and pumped against the diaphragm during the remaining half. This type of drive is often called "hydraulic lost motion," because a portion of the piston's travel does not transmit pumping energy when the capacity adjustment is less than 100%. Both the mRoy and the Maxroy are hydraulic by-pass style pumps. Both develop reciprocating piston motion by way of a worm gear set and eccentric.

mRoy A, mRoy B

In the mRoy, the piston pumps hydraulic fluid, which either forces the diaphragm to flex, or is relieved through the by-pass port. A control valve positions the port based on a desired capacity setting.

The mRoy drive with its standard disc diaphragm liquid end features:

- Simplex or Duplex liquid ends
- Maximum capacities ranging between 0.43 GPH and 85 GPH (170 GPH Duplex)
- Maximum pressures up to 1800 psi

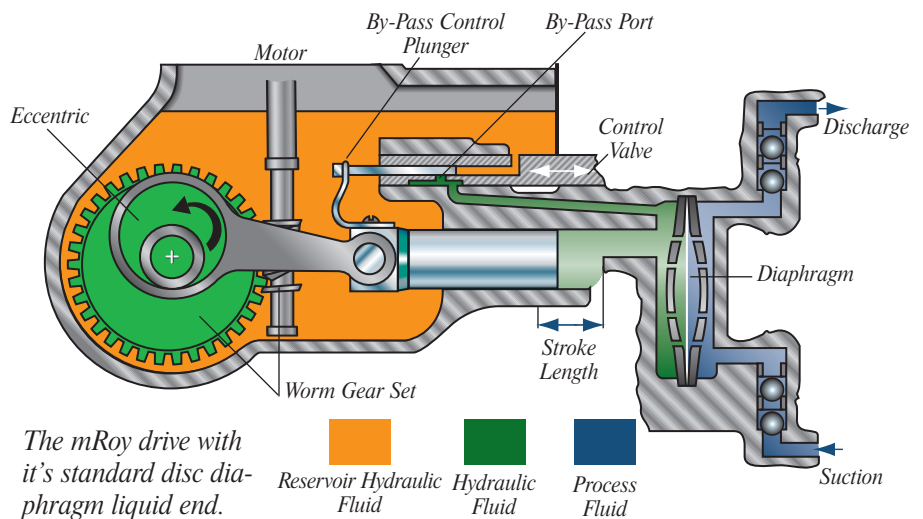

The mRoy drive with its standard disc diaphragm liquid end.

maxRoy B

In the maxRoy, capacity is varied by positioning a stroke adjust sleeve over by-pass ports bored through the hollow piston. When operating at 100%, the ports are covered, which traps hydraulic fluid in the hydraulic pumping chamber. Once trapped, the piston's pumping action forces the hydraulic fluid to flex the diaphragm.

A cup valve, which is attached to the diaphragm, closes all hydraulic paths to the diaphragm when it has reached the full forward position. This eliminates a process contour plate, as well as excessive hydraulic pressure on the diaphragm, since any excess hydraulic fluid in the hydraulic pumping chamber cannot reach the diaphragm, and is forced through the internal relief valve to the fluid reservoir.

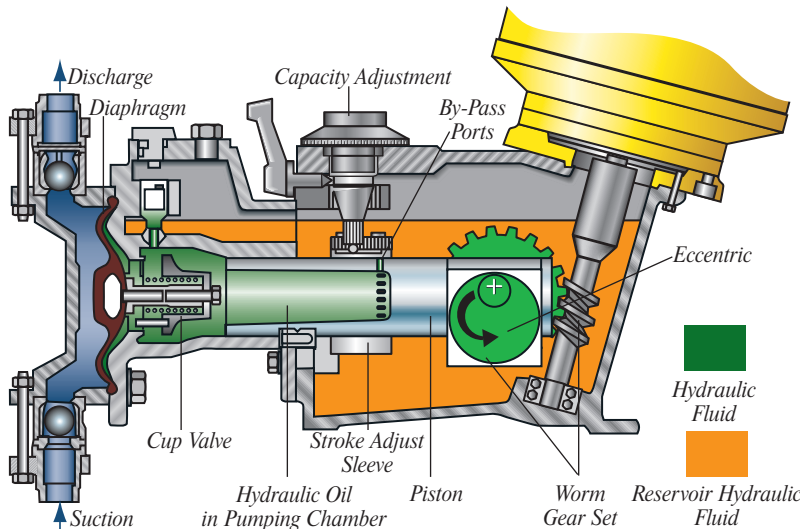

The maxRoy drive features:

- Maximum flow rates between 135 GPH and 227 GPH
- Maximum discharge pressures of 150 psi

The maxRoy is an excellent choice for mid-range metering pump capacity at low pressure. Its design is more economical than high pressure pumps in the same capacity range, without sacrificing ruggedness and accuracy. The "straight through" process fluid path allows maxRoy to be applied to many of the same services as the HPD liquid end.

Polar Crank

The unique polar crank drive is the heart of the Milroyal series metering pump. It is considered the most advanced and reliable variable stroke length drive available in high pressure/high flow industrial duty metering pumps.

In the polar crank drive, a high speed worm gear reduces the RPM supplied by the motor, and provides the lower RPM to a rotating crank. A connecting rod with spherical bearings on each end links the crank to the crosshead and piston assembly.

The worm gear and crank assembly pivots in an arc about the worm shaft center to change stroke length. The piston stroke length is determined by the angle of the assembly.

For example, when the pump is at zero stroke, the worm/crank assembly is in a vertical position. (Figure 1) The crank then rotates in a vertical plane and one end of the connecting rod revolves with it. The crosshead and the piston remain stationary because no reciprocating action is produced. When the pump is adjusted full stroke (or maximum capacity), the rotating crank is moved to its maximum angle from the vertical axis. (Figure 2) At the top of the rotation cycle the connecting rod is pushed forward, moving the crosshead and

piston to the full forward position at the end of the discharge stroke. As the crank continues to rotate, the angle of the crank causes the connecting rod to pull the crosshead and piston until it reaches the full rearward position at which point the connecting rod has reached the bottom of the rotation cycle.

Regardless of the stroke length setting, the top of the rotation cycle always forces the crosshead and the piston to the full forward position at the end of each discharge stroke. This assures complete scavenging of the liquid end during each stroke cycle.

The angle of the polar crank can be adjusted in infinite increments

between zero and maximum stroke for extremely accurate controlled volume pump settings.

The Milroyal polar crank drive features:

- Maximum capacity ranges between 0.033 GPH (125mL/hr.) and 2510 GPH depending on frame size, stroking speed, and plunger diameter
- Discharge pressures up to 7500 psi
- Up to 8 pumps multiplexed and driven by one motor
- HPD, packed plunger, disc diaphragm, or tubular diaphragm liquid ends

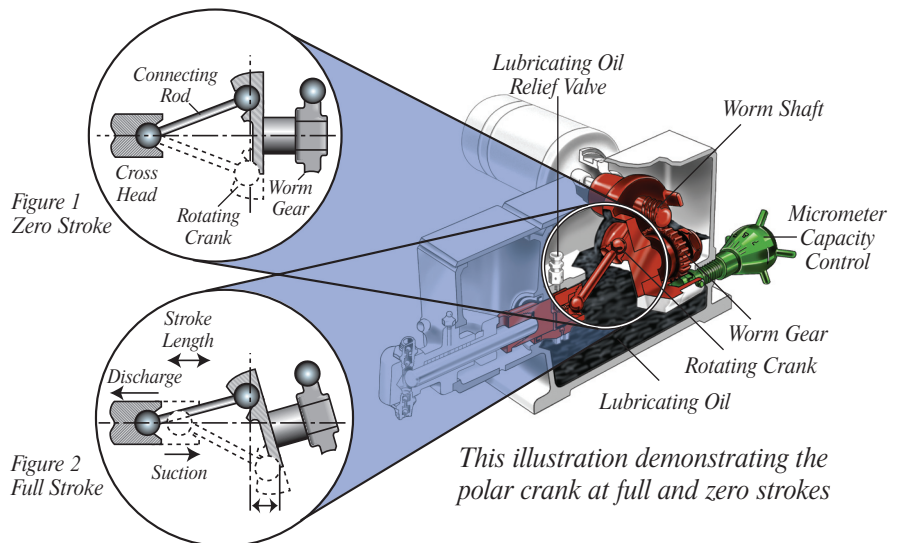

This illustration demonstrating the polar crank at full and zero strokes

Pressurized Lubrication System

To achieve a high thrust capacity and extend component life, the Milroyal B and C polar crank drives feature a pressurized lubrication system.

This positive oil pressure lubrication ensures long bearing life and permits the Milroyal pump to operate at very high suction and discharge pressures.

As the crosshead moves forward during the discharge stroke, oil from the reservoir is drawn up through a ball check into a cavity in the

crosshead. During the suction (rearward) stroke the lubricant is trapped. It is then forced through the crosshead, into the crosshead connecting rod bearing, through the hollow connecting rod, and finally to the crank connecting rod bearing. By forcing the oil through this path, every moving part is lubricated during every complete cycle of the pump.

To reduce the wear of moving parts and extend oil life, a magnetic strainer cleans the oil before it enters the pressurized system.

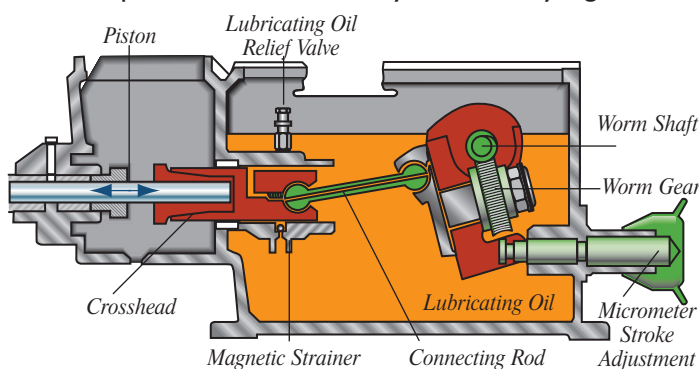

CENTRAC – The Automatic Process

Advanced Drive Technology

Centrac represents a new concept in metering pump drive design. It is the first true innovation in metering pump drives to be introduced in decades.

Centrac was developed by combining the highest level of gear reduction design, and the latest technology in electronic variable speed drives. The

result is a metering pump that boasts twice the accuracy over a turndown ratio ten times greater than traditional designs.

Centrac's name clearly announces its capabilities:

- CENT-100:1 turndown ratio
- R-Response & Reliability
- AC - $\pm 0.5\%$ steady state accuracy

Centrac is different from traditional designs in many ways. The most significant way is the close relationship between the driver and drive mechanism and how they enhance overall pump performance. To understand Centrac better, these two design elements and their interdependence need to be explored.

Centrac's Unique Gear Reduction System

Centrac's impressive operating characteristics are the result of a unique constant stroke length drive mechanism that depends on a special electronic variable speed drive to vary pump flow rate. This offers a number of advantages.

Traditional designs utilize worm gear sets to convert motor rotation to reciprocating motion through an eccentric or similar mechanism. Worm gears are the best choice when the drive mechanism is

required to incorporate a variable stroke length adjustment. They operate well at high rotary speeds, due to an oil shield that develops between the gear surfaces. Unfortunately, they lose that shield at lower speeds, which causes wear and raises motor torque requirements. This limits worm gears to a 10:1 turndown ratio.

Centrac, on the other hand, utilizes a special helical gear set. Since there is no need for stroke length adjustment, the gear set is very simple. Also, helical gears are known for operating with low noise and low friction. Combined with a basic scotch yoke mechanism to develop

reciprocating motion, this gear set runs quietly and efficiently with few moving parts. All moving parts are submerged in oil to ensure long life.

The graph below indicates the greatest advantage of Centrac's special gear design. The flat torque curve (vs. the worm gear set) allows Centrac to operate at or below 1% of speed without placing extra demand on the motor, thus permitting Centrac's 100:1 turndown ratio.

The simple drive mechanism also

allows Centrac to be easily duplexed within the same housing by adding a second piston and liquid end opposite the primary liquid end. Centrac's capacity can therefore be doubled economically and efficiently.

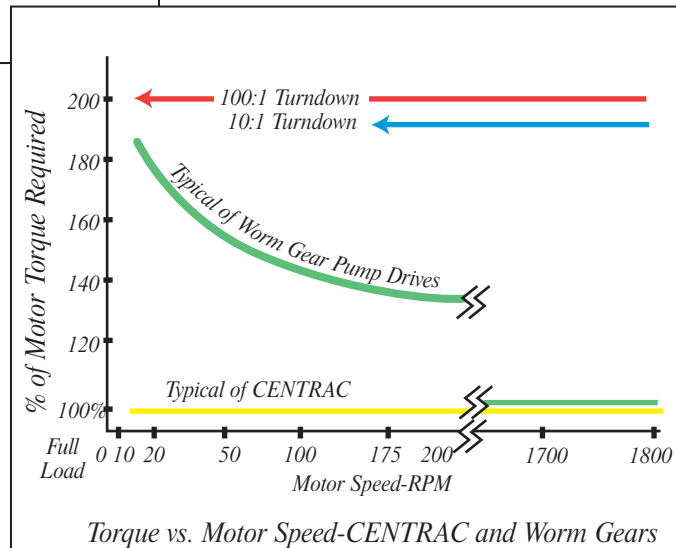
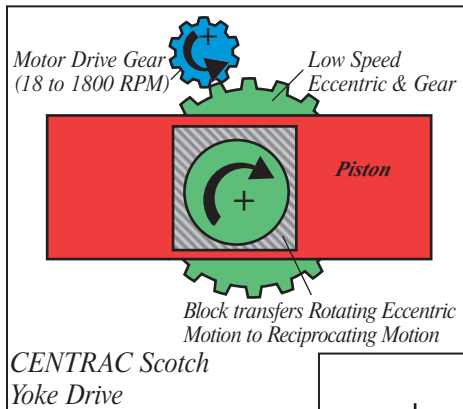

Operator Control Station

Centrac's Advanced Electronic Variable Speed Drive

Conventional AC and DC variable speed drives are limited to turndown ratios between 5:1 and 30:1. This is insufficient to take advantage of the turndown capabilities of Centrac's gear design.

New technology in brushless DC motors and controllers has created advanced drives capable of strong operation at low speeds. Centrac's

variable speed drive delivers rated torque at less than 1% (100:1 turndown) of maximum rated RPM while maintaining steady state speed control at better than $\pm 0.1\%$. It is the perfect match for Centrac's drive mechanism.

Metering Pump

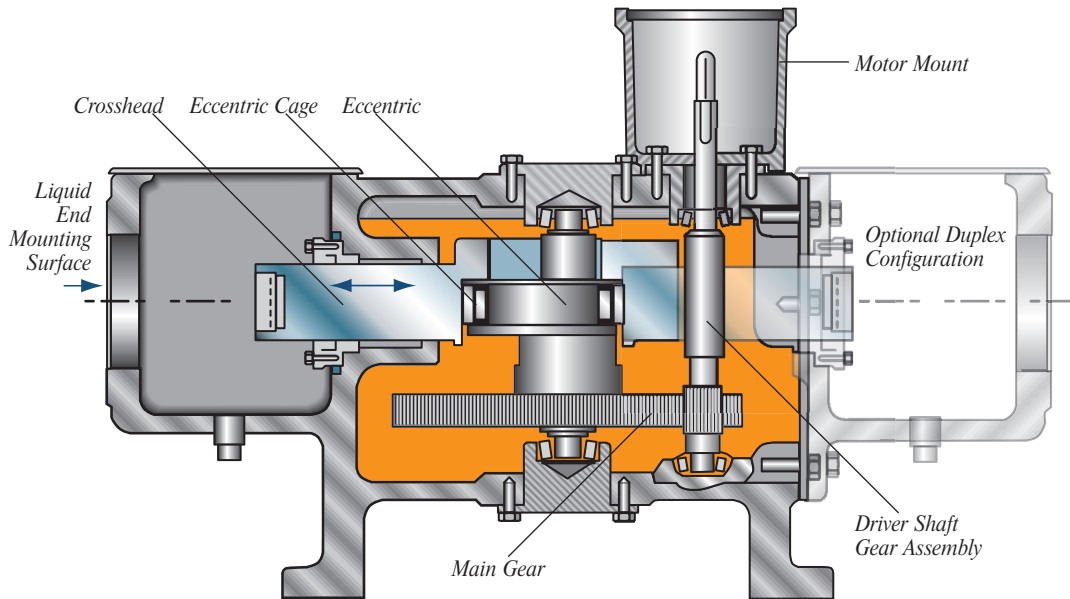

Centrac's variable speed drive features:

- 100:1 turndown ratio
- $\pm 0.1\%$ steady state speed control
- smart commutation - permits accurate feedback signal
- no brushes (low maintenance)
- constant torque at low speeds - permits efficient driver sizing

100:1 Turndown Ratio

The flexibility of a 100:1 turndown ratio permits Centrac to be applied where a wide range of dosage rates are required. It also provides built-in growth potential by pumping efficiently in systems requiring a fraction of the pump's capacity for the short term during start-up or early phases of an expanding project. Centrac provides all this without compromising accuracy or drive power.

Response

Centrac responds instantly to changes in dosage rate. Its constant stroke length does not upset the balance within the liquid end hydraulic system, that is, hydrau-

lic fluid volume remains constant. When the hydraulic balance is disturbed, as in variable stroke length designs, the full result of dosage changes can take minutes or hours.

Centrac's instant response provides smoother operation in closed loop or automated systems. It also assures proper dosage at all time in systems requiring very close dosage tolerance.

Accuracy

Centrac's $\pm 0.5\%$ steady state accuracy over its full turndown ratio is a result of the constant stroke length, and the precise speed control of Centrac's drive. This level of accuracy provides maximum chemical economy while assuring stable automatic operation and optimum process quality.

Centrac's features include:

- 100:1 turndown ratio
- $\pm 0.5\%$ steady state accuracy
- Instant response to dosage changes
- Simple but robust design for reliability
- Precise feedback signal
- Efficient drive sizing
- Mates with advanced HPD liquid end for maximum performance
- Capacity range between 0.45 GPH minimum and 1100 GPH maximum
- Discharge pressures up to 1575 psi
- Economical duplex configuration availability
- Compact design higher capacity in a small footprint

Connection Diagram

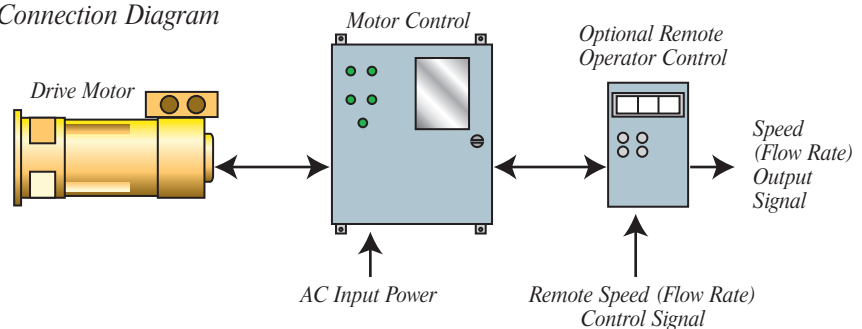

Capacity Adjustment

Metering pumps allow the user to vary capacity as the process requires. All Milton Roy metering pumps permit adjustment whether the pump is running or not.

With the exception of the Centrac (see Centrac drive), Milton Roy pumps are supplied with a manual micrometer for performing manual capacity adjustments. Depending on the type of drive mechanism and the application requirements, one of several capacity adjustment options can be supplied.

Manual Micrometer

The manual micrometer can be used to adjust the metering pump's capacity anywhere between 0 and 100%. While not directly proportional to flow, this calibrated adjustment can be used to accurately set pump capacity based on the pump performance curve within $\pm 1.0\%$ over the turndown ratio.

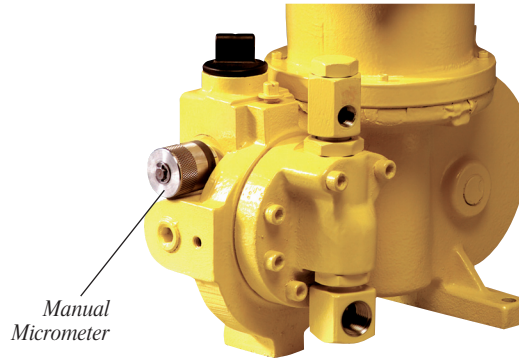

Electronic Actuator

Option Available for: mRoy A & B, MaxRoy, Milroyal B & C

The Milton Roy Electronic Actuator responds to electronic process signals or remote manual adjustments. In addition, a local handwheel is provided to permit manual adjustments when unpowered.

Milton Roy's electronic actuator is different from electric actuators in that it utilizes electronic limits. It is built around stepper motor technology, which allows it to travel precisely to position without overshoot or hunting.

This design also provides superior operating characteristics such as:

- 100% duty cycle
- $\pm 0.5\%$ position accuracy or better
- low maintenance

Remote control stations are available for local/remote selection and manual capacity adjustment.

Specifications:

- NEMA 4 (Explosion proof available)
- 4-20 mA input signal standard
- Direct or reverse acting
- 1-5 VDC stroke position output signal
- Single phase 50/60 cycle 115 VAC

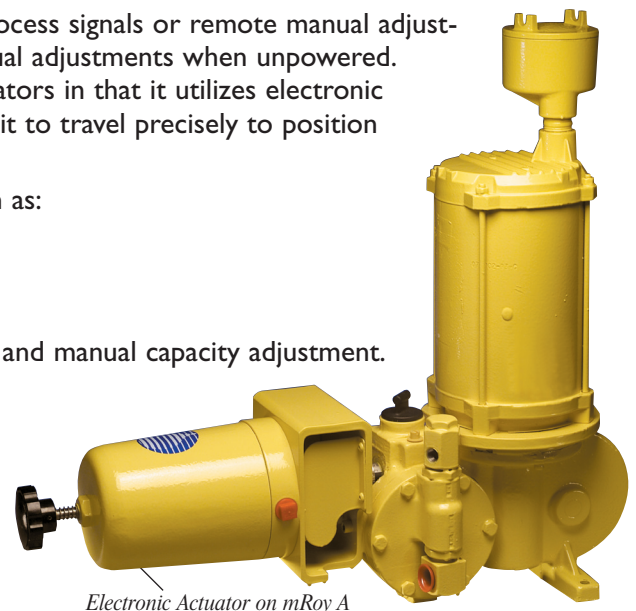

Pneumatic Actuators

Option Available for: mRoy A & B, Milroyal B & C

Automatic systems that supply a pneumatic process signal benefit from the Milton Roy pneumatic actuator. A separate air control panel is available for remote control and auto/manual switching.

Specifications:

- 3-15 or 3-27 psi pneumatic signal
- Direct or reverse acting
- Requires 60 psi supply air pressure

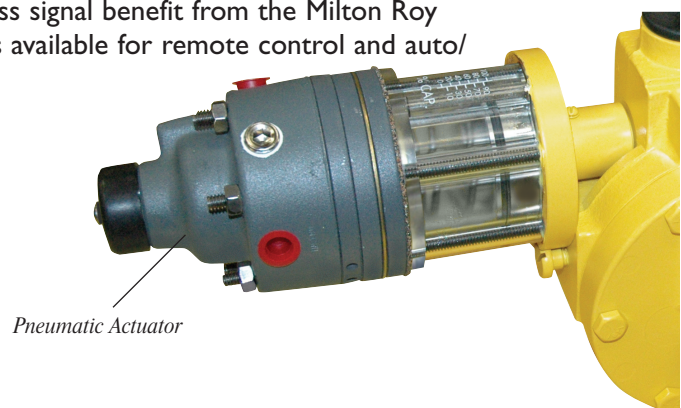

Modifications

Double Diaphragm With Diaphragm Rupture Detection System

Milton Roy's diaphragm liquid ends are, by design, leakproof and durable. In some applications, however, added assurance is desired to protect the pump from hostile chemicals, or protect the process from contamination by hydraulic fluids. For these situations, Milton Roy has developed a highly reliable diaphragm rupture detection system.

The system consists of two separate diaphragms, a hollow intermediate ring, and a pressure gauge or switch. During the normal opera-

tion, the two diaphragms are pushed tightly together and are separated only around their outside edge by the intermediate ring. The rupture detection system senses a pressure only when a diaphragm ruptures. The system is not affected by changes in pump discharge pressures.

This system is available for mRoys, maxRoys, MacRoys, and HPD's. A different design centered around sensing changes in conductivity is also available for a number of liquid ends.



Application Engineering: Custom Modifications

Milton Roy offers a wide variety of standard pumps to satisfy most applications. In addition, our Applications Engineering department is capable of supplying specialty engineered products.

Capabilities include:

- Special liquid end materials including diaphragms, diaphragm heads, check valves, etc.
- Special piston diameters
- High temperature or pressure modifications
- Unique multiplex arrangements
- Application counseling
- Special sensors, indications, or instrument interface
- Special drive modifications or gear ratios

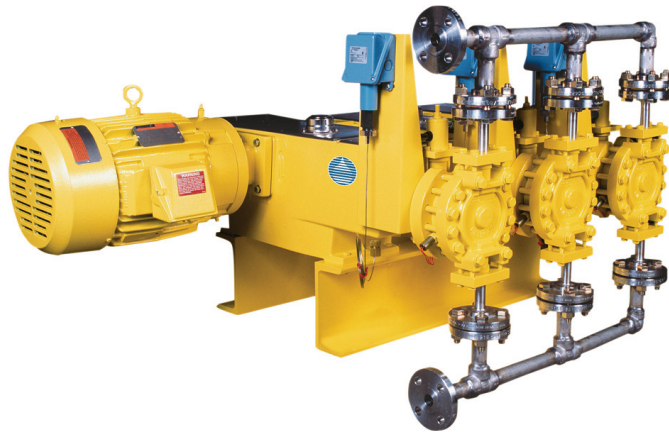

Metering Pump System Components

Proper metering pump system operation depends upon the selection of appropriate system components. Milton Roy offers high quality accessories to suit your application requirements.



1. Safety Relief Valves

Most piping systems require the use of an external safety valve to protect the piping from over-pressure. Diaphragm pumps feature internal safety valves to protect the pump, but external safety valves are still recommended. Milton Roy provides safety relief valves to match the operating pressures of all pumps we manufacture. Standard safety relief valves are available in specialty steel, 316 SS, alloy 20, and PVC.



2. Back Pressure Valves

To prevent unmetered liquid from free-flowing through the pump, metering pump systems require a greater pressure in the discharge line than the suction or inlet line. When the process does not supply a minimum of 25 psi above the suction pressure, a back pressure valve is required. Standard back pressure valves are available in specialty steel, 316 ss, alloy 20 and PVC .



3. Pulsation Dampeners

The metering pump's reciprocating motion provides a pulsating discharge flow. Applications requiring a steady flow can eliminate over 90% of the pulsations with a pulsation dampener. Dampeners are available for pressures to 1000 psi. Sizing is based on cubic inch/stroke displacement of the specific pump.

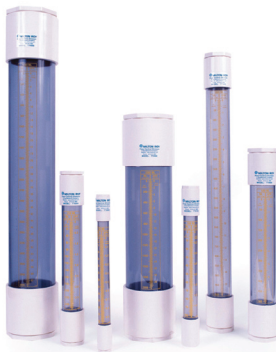

4. Calibration Columns

All Milton Roy metering pumps are factory tested. Once installed, pump calibration should be periodically determined to verify proper operation, especially after the performance of any maintenance. Milton Roy calibration columns provide an inexpensive means of assuring pumping accuracy.



5. Mixroy® Mixers

Accurate dosing requires proper mixing of the solution being pumped. Mixroy® mixers are direct drive, high speed units designed for mixing medium and low viscosity fluids and dispersion of light solids.



6. Tank Chemical Feed Systems

Milton Roy offers tanks (in most available tank capacities) in steel, stainless steel, and polyethylene. They are also available with pumps and mixers mounted, plumbed, and ready for installation.

Typical Installation

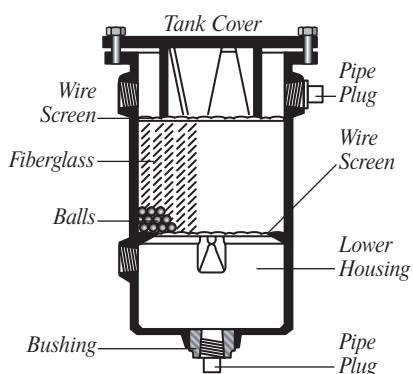
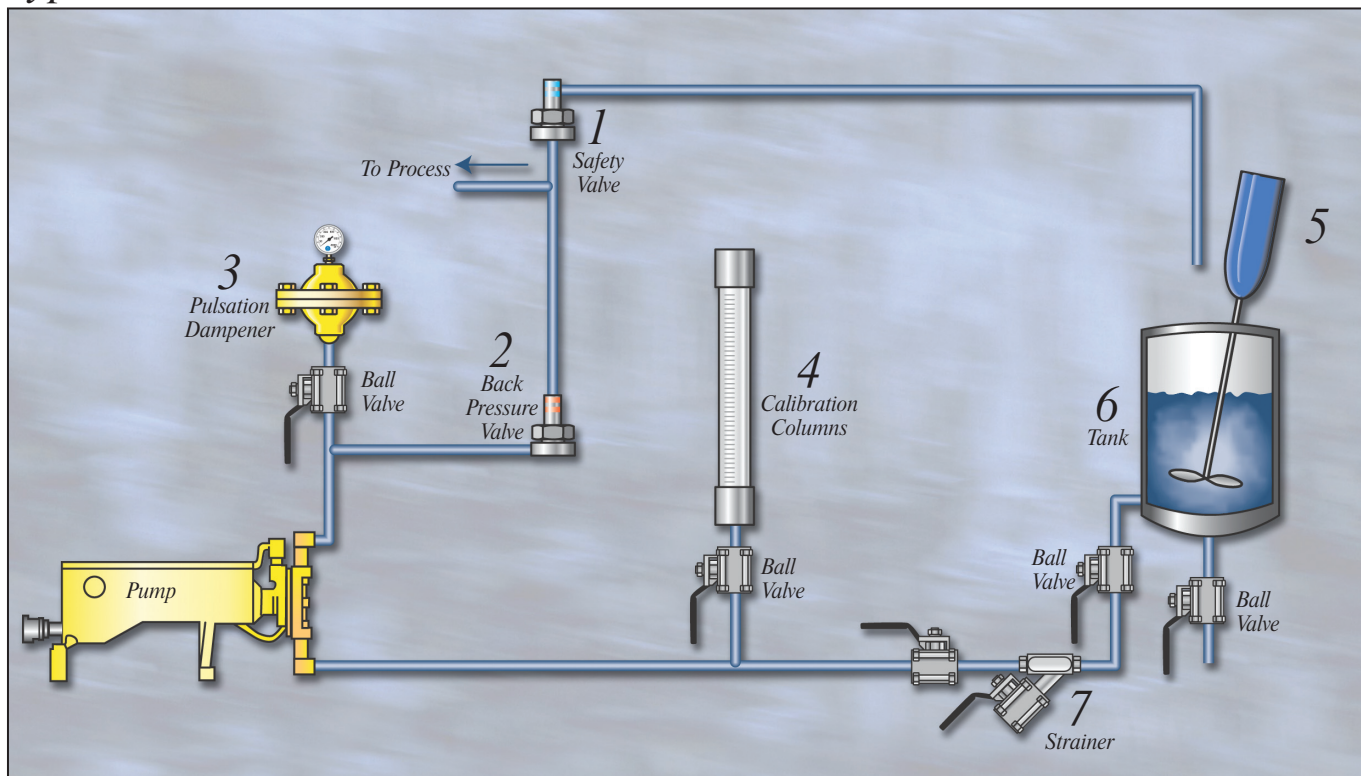

7. Strainers/Sludge Traps

The metering pump's check valves should be protected from particles and debris by installing a strainer in the suction line.

When pumping concentrated sulfuric acid, a sludge trap is required to trap sludge particles while providing easy cleaning or flushing.

Foot valves and strainers are available for applications that pump fluid from replaceable drums. "Y" type strainers can also be supplied for in-line protection in standard systems.

8. Chemical Dosing Systems

Milton Roy offers the "RoyPak" family of chemical dosing pre-engineered systems. The standard RoyPak provides manual control and all accessories to allow for proper operation.

The RoyPak *Setpoint* paces the dosing from your single input. The RoyPak *Setpoint Plus* uses a line of instruments to provide a full closed-loop solution.

Other Milton Roy Products

Streaming Current Detector

Milton Roy's Streaming Current Detector (SCD) is used to monitor and control coagulants in water or wastewater treatment. The SCD is an on-line instrument, therefore consistent effluent quality is assured.

In addition to water and wastewater treatment, the SCD is widely used in paper making, petroleum, food, chemical, and other industries where close control of coagulant or charge altering chemicals are beneficial.



The Milton Roy Family of Streaming Current Detectors

Electronic Actuators

A broad line of electronic actuators, similar to those used on Milton Roy pumps, is available for control valve actuation and other applications requiring precision and dependability. These advanced electronic actuators outperform standard electric designs by utilizing stepper motor technology.

Milton Roy's electronic actuators offer the following advantages:

- 100% duty cycle
- Electronic limit switches
- Direct to position operation-no hunting or overshoot
- Rotary or linear designs
- AC and DC units
- Responds to 4-20 mA, split range, digital and other process signals
- Maximum torque - 3800 in-lbs (317 ft-lbs)
- Maximum thrust - 1100 lbs
- Optional controllers and failsafe units



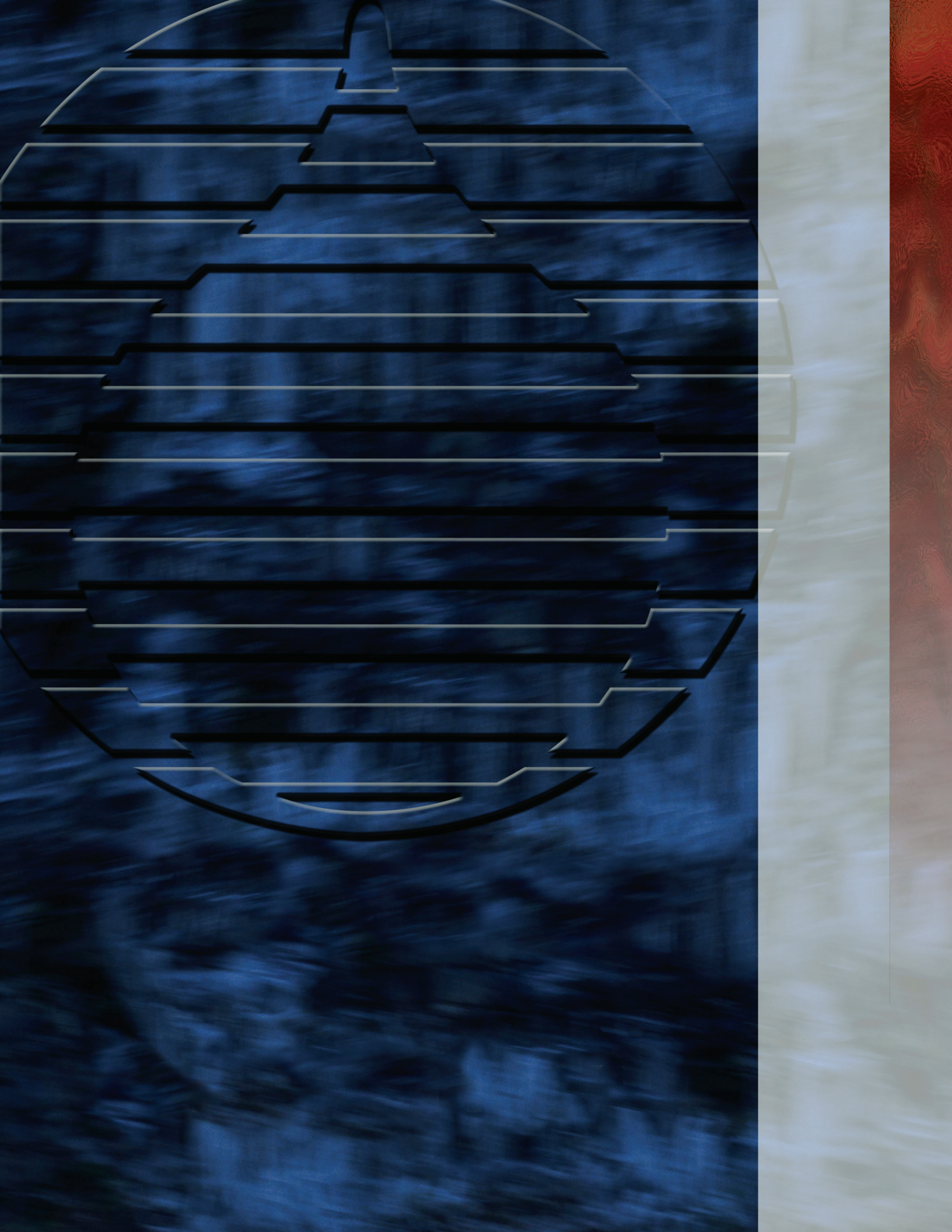

Milton Roy Metering Pump Technology

Bulletin 210
Revision C 7/08

Teflon® is a registered trademark of
E. I. du Pont de Nemours and company
or its affiliates.



MILTON ROY

201 Ivyland Road
Ivyland, PA 18974-0577
215.441.0800
Fax: 215.441.8620
www.miltonroy.com