

PRIMEROYAL[®]

Series Metering Pumps

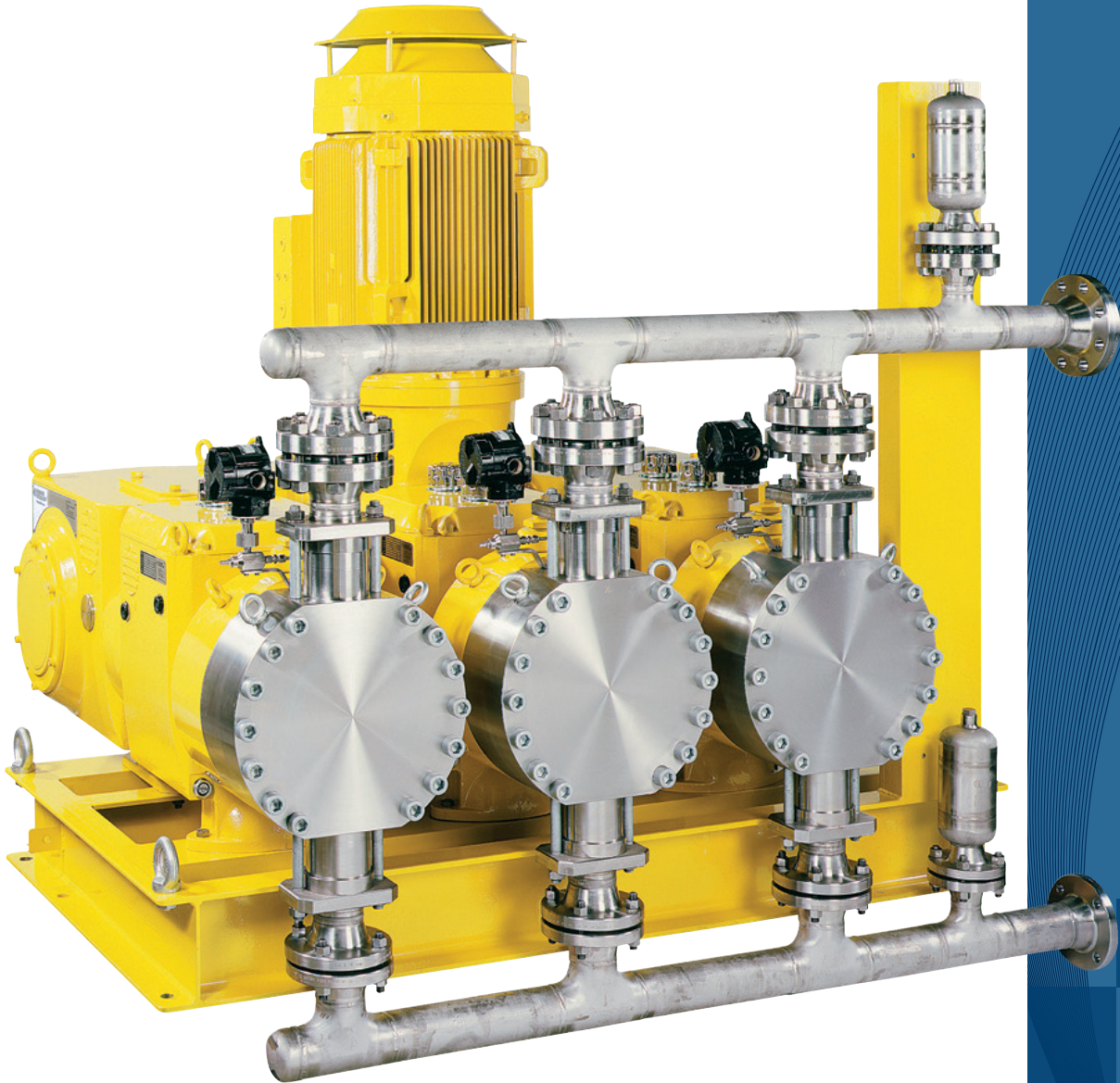

The Force in Pump Technology

PRIMEROYAL[®] series metering pumps

Unsurpassed reliability and versatility in critical chemical dosing applications

The outstanding reliability of Primeroyal series pumps begins with a robust gear mechanism and a modular design. These highly flexible pumps accept several types of liquid ends and capacity-control options for the specific requirements of your application. More than a half-century of experience combines with advanced pump-engineering technologies to give you continuous operation with the longest possible time between scheduled maintenance.

The combination of robust, field-proven design and flexible modularity makes Primeroyal pumps suitable for a large number of industrial processes. The Primeroyal range provides accurate dosing of a broad spectrum of fluids at flow rates that can reach more than 25,941 l/h (6,853 gph) in the triplex configuration.

With its versatile, modular design and wide range of options, Primeroyal pumps can be precisely configured for your applications.







A history of reliability

With over 75 years of experience, Milton Roy combines vast industry experience, a proven track record, and a culture of continuous technological improvement to provide customized solutions for all pump applications. Milton Roy delivers the market's most reliable, comprehensive range of metering pumps. Every one of our pumps is engineered to exceed expectations and is backed by a global network of highly trained field engineers and after-sales support that is second-to-none.

Primeroy® and Primeroyal® Range

Selection chart

Liquid End		Packed Plunger				Metallic Diaphragm				PTFE Diaphragm					
		NX		UT or N		MX		M		HX		H		P	
		Max. Flow l/h (gph)	Max. Pressure bar (psi)	Max. Flow l/h (gph)	Max. Pressure bar (psi)	Max. Flow l/h (gph)	Max. Pressure bar (psi)	Max. Flow l/h (gph)	Max. Pressure bar (psi)	Max. Flow l/h (gph)	Max. Pressure bar (psi)	Max. Flow l/h (gph)	Max. Pressure bar (psi)	Max. Flow l/h (gph)	Max. Pressure bar (psi)
	PK	37.5 (9.91)	930 (13,488)	2,062 (544.8)	300 (4,351)			195 (51.5)	500 (7,252)			330 (87.2)	151 (2,190)	330 (87.2)	10 (145)
	PKG											2,500 (660.5)	37 (537)	2,500 (660.5)	10 (145)
	PL	86.3 (22.8)	1,000 (14,504)	3,480 (919.4)	309 (4,482)	66 (17.44)	1,034 (14,997)	242 (63.9)	500 (7,252)			4,410 (1,165)	286 (4,148)	3,561 (940.8)	8 (116)
	PLG											3,300 (871.9)	45 (653)	2,657 (702)	10 (145)
	PN	265 (70)	1,000 (14,504)	9,863 (2,606)	244 (3,539)	363 (95.9)	1,379 (20,001)	230 (60.8)	500 (7,252)			8,649 (2,285)	300 (4,351)	6,791 (1,794)	10 (145)
	PP			15,665 (4,139)	306 (4,438)							10,056 (2,657)	300 (4,351)		
	PR	793 (209.5)	1,000 (14,504)	15,659 (4,137)	319 (4,627)	793 (209.5)	1,379 (20,001)			992 (262.1)	397 (5,758)	12,549 (3,316)	300 (4,351)		
	PX	1,268 (335)	980 (14,214)			1,980 (523.1)	1,372 (19,899)			8,647 (2,285)	252 (3,655)				

The values are based on a 50Hz motor. For a 60Hz motor, the values increase by approximately 20% so please consult your representative to verify.

General Specifications

- Flow rate: from 0.2 l/h (0.05 gph) to 12.5 m³/h (3,315 gph) in simplex configuration
- Pressure: up to 1,379 bar (20,000 psi)
- Multiplexable
- Accuracy: ±1%, even for low flow rates and high pressures
- Fluid temperature: from -30°C to 110°C (-22°F to 230°F) as standard/up to 315°C (600°F) on request
- Ambient operating temperature: Standard -10 °C to 50°C (14°F to 122°F). Low temperature option: -40 °C to + 50 °C (-40°F to 122°F)
- Stroke adjustment: from 0 to 100% of nominal flow rate
- Explosion-proof version: conforming to ATEX CE EX II 2 G/D c T3 or T4 upon request
- Standard liquid-end materials include: 316L, PVC, 17-4ph, and Alloy 20

Applications

Primeroyal metering pumps are preferred in a wide range of industries:

- Oil and gas production, transportation, and refining
- Chemical and petrochemical processing
- High-flow municipal water treatment
- Industrial water treatment
- Power generation
- General Industry

Features and Benefits

Why Primeroyal pumps are your best choice

Reliability, Precise Control

Innovations such as the variable eccentric drive combine with proven experience in metering pump technology to give you the highest reliability in the most critical applications while performing with high repeatable accuracy.

- Built to API 675 standards
- Maximum performance in a small footprint
- Diaphragm liquid ends guaranteed leakproof with service life in excess of 20,000 hours
- Field-proven operation under low temperatures or offshore applications
- Can pump a wide range of chemicals including acids, bases, corrosive or viscous liquids, and slurries

Performance Ratings of Triplex Primeroyal Pumps

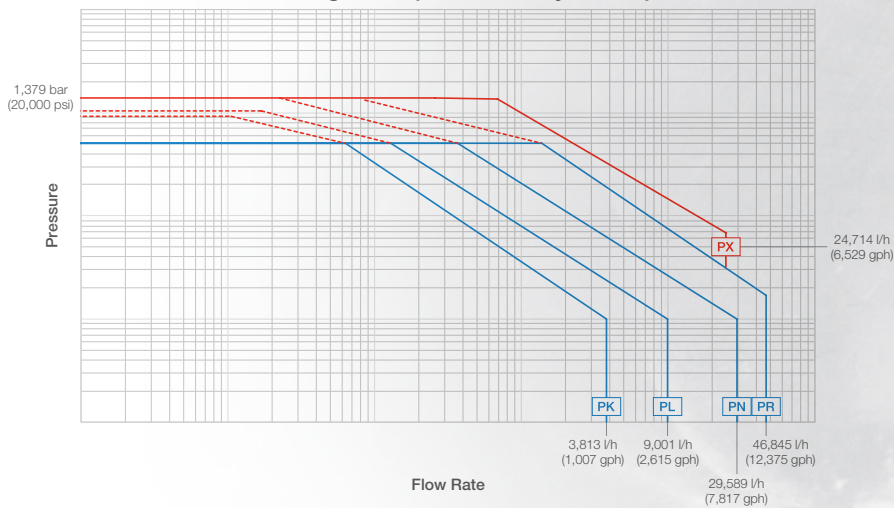

The blue line indicates former pump pressure performance.
The red dotted line shows the extended performance ratings of the Primeroyal pump series.

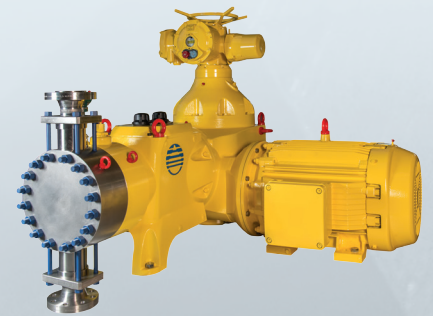

The Primeroyal X with metallic liquid end and PTFE (Teflon®) double diaphragm, horizontal motor configuration, and actuator with integrated electronics.



PrimeRoyal L Simplex with HPD liquid end

Flexible Design

With its versatile, modular design and wide range of equipment and material options, Primeroyal pumps are an integrated pump system that can be precisely configured for your applications.

- Five frame sizes with a wide flow rate and pressure range
- Selection of liquid-end types and operation option
- Multiplexing available in any combination of frame sizes
- Variable or fixed stroke length
- Adjustable flow manually or electronically while running or stopped



Primeroyal R Triplex Configuration

Compact and Durable Variable Eccentric Drive

In critical processes, the Primeroyal variable eccentric drive assures compactness, durability and optimum performance for the entire chemical dosing system.

This innovation is a no-lost-motion design compared to designs that have stop plates or rods to limit the plunger travel. Lost-motion designs also rely on spring return mechanisms to keep the plunger in contact with the eccentric. Primeroyal pumps power the full stroke cycle, which eliminates the mechanical and hydraulic shocks inherent in lost-motion drives.

The Primeroyal variable eccentric drive enables precise control of the pump delivery rate while meeting or exceeding industry standards for steady-state accuracy and repeatability. Primeroyal pumps achieve this high level of performance in a compact size, for the greatest installation flexibility.

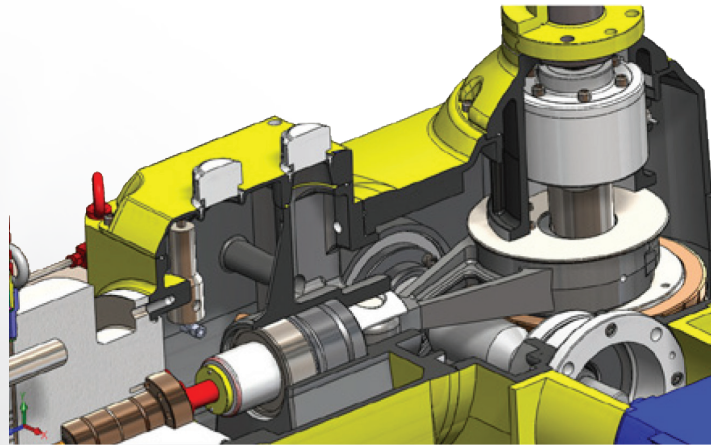

Responsive Support

Our outstanding team of highly-competent engineers, technicians, and partners can provide world-class service and support. Not only can we assist you in selecting the optimal pump to meet your requirements, but we can deliver service throughout the pump's lifecycle from installation to after-sales support.

- Project management and packaging services
- Installation and commissioning of your pump
- Manufacturer's documentation including material certifications, drawings, parts list, etc.
- Testing services such as hydrostatic, vibration, noise, X-ray, etc.
- Spare parts and repair services for preventative and critical maintenance

Options

Liquid Ends

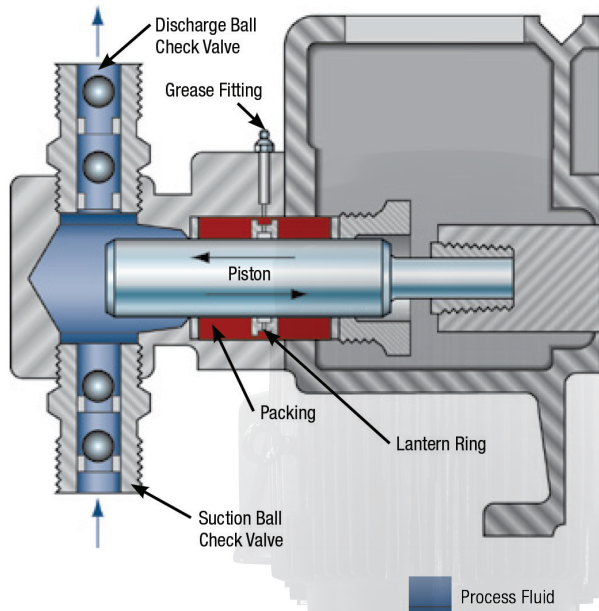

Packed Plunger Liquid Ends Models UT, N, or NX

The packed plunger liquid end offers the best performance when net-positive inlet pressure is an issue. The plunger is in direct contact with the process fluid, to provide the most efficient pumping performance.

- Ideal for viscous fluids and slurries
- 3 psia net positive inlet pressure required
- Options available to handle temperatures as high as 315°C (600°F)
- Pressures up to 1,000 bar (14,504 psi)
- Standard plungers provide long plunger life in excess of 20,000 hours
- Model NX assures leak-free operation

Metallic Double Diaphragm Liquid Ends Models M or MX

Milton Roy's metallic diaphragm liquid end easily handles the most severe high-pressure, high-flow applications:

- High pressure applications up to 1,379 bar (20,000 psi)
- Hydraulically balanced diaphragm minimizes stress
- Standard diaphragm material is 301 or 316L stainless steel. Modified materials are available to suit the process fluid
- Sealless liquid-end design assures leak-free operation
- Dosing of specific products such as radioactive or diffusing liquids
- Internal safety valve: patented, differential pressure valve with integrated air bleed. Adjustable pressure setting
- Assembly designed for service life in excess of 10,000 hours
- Oil compensation valve with adjustable pressure setting

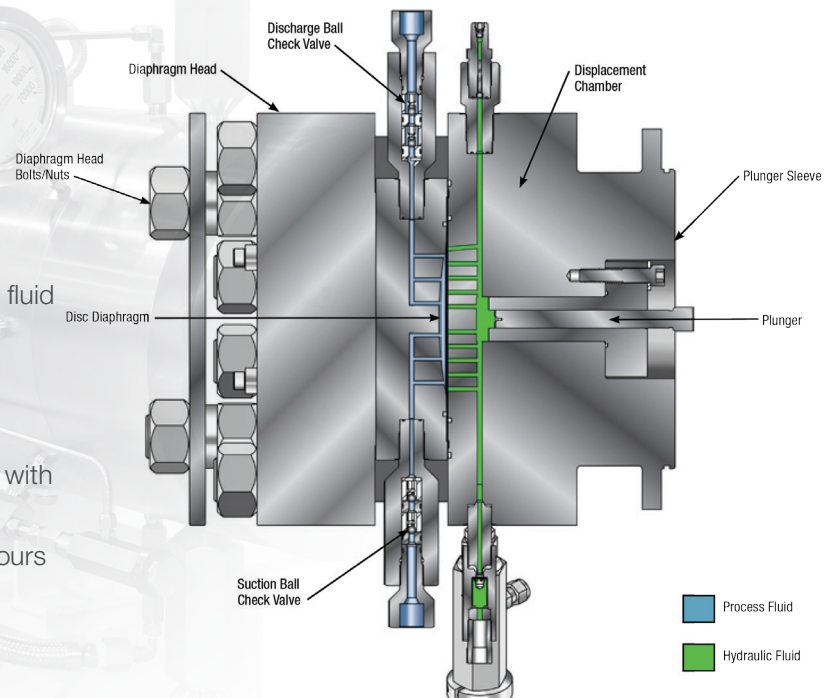

PTFE Double Diaphragm Liquid Ends

Models H, HX, or P

Milton Roy's proven High Performance Diaphragm (HPD) liquid end combines the best characteristics of traditional liquid ends with a simple and elegant design.

- Hydraulically balanced diaphragm minimizes stress and assures long diaphragm life
- Diaphragm PTFE wetted surface provides wide chemical compatibility with process fluids while composite materials allow maximum flexibility
- Adjustable internal relief valve in hydraulic system protects pump from overpressure
- Patented MARS hydraulic fluid compensation system eliminates the need for process side diaphragm containment that restricts flow
- 316L stainless steel or PVC version with single or double diaphragm
- Handles pressures up to 379 bar (5,758 psi) without impact on diaphragm life
- Completely leakproof
- Self-formed PTFE/elastomer compound diaphragm or molded preformed PTFE diaphragm, depending on model
- Patented reusable diaphragm. Service life in excess of 20,000 hours

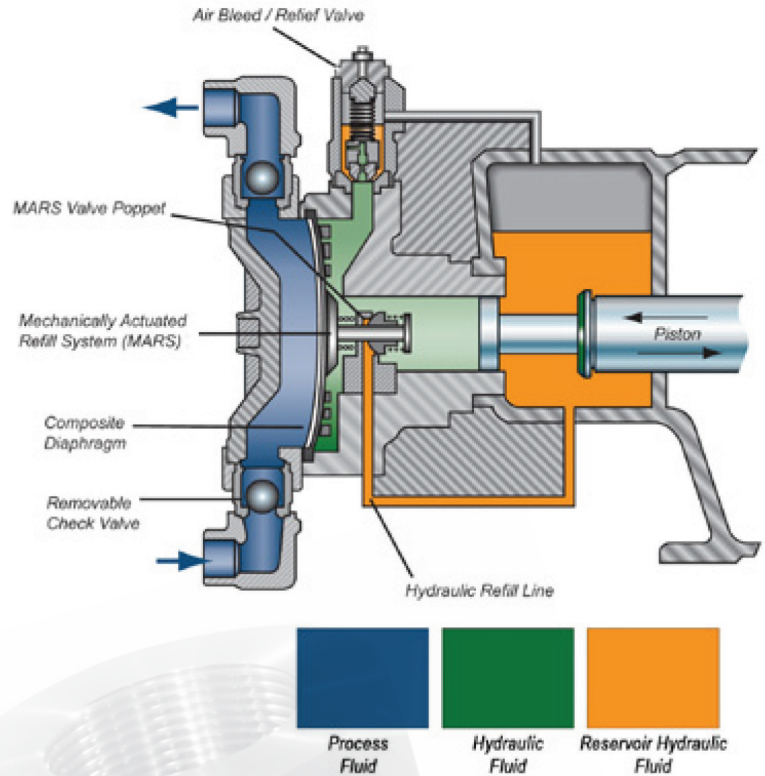

Design Options

The Primeroyal series offers options to meet the requirements of most applications including, but not limited to:

- Electronic capacity control by actuator
- Variable speed drive control
- Flanged, NPT, and other connections as required
- Specified liquid end materials
- Special base plates
- Diaphragm Rupture Detection system
- Steam or cooling jackets
- Remote head
- High and low temperature configurations
- Low temperature options
- NEMA and IEC flange motor mount options
- Special check valves for all types of fluid (including concentrated sulphuric acid)

We are a proud member of Accudyne Industries, a leading global provider of precision-engineered, process-critical and technologically advanced flow control systems and industrial compressors. Delivering consistently high levels of performance, we enable customers in the most important industries and harshest environments around the world to accomplish their missions.



To learn more about the Primeroyal series of metering pumps, contact your local representative or visit our website.

www.miltonroy.com

Americas

201 Ivyland Road
Ivyland, PA 18974, USA
Tel: (215) 441-0800
Fax: (215) 441-8620

info@miltonroy.com
www.miltonroy.com

Europe, Middle East, Africa

10 Grande Rue
27360 Pont-Saint-Pierre, France
Tel: +33-(0) 2-32-68-3000
Fax: +33-(0) 2-32-68-3093

mr14.contact@miltonroy.com
www.miltonroy-europe.com

Asia

Plot No: P 45/1
Domestic Tariff Area 8th Avenue
Mahindra World City
Chengalpattu - 603 002, India
Tel: 91-44-2225-4000 to 3
Fax: 91-44-2225-4004

miltonroyindia@vsnl.net
www.miltonroyindia.com

23 Tagore Lane #03-06
Tagore 23 Warehouse Complex
Singapore 787601
Tel: 65-6242-9182

mrapsing@miltonroy.com.sg
www.miltonroy.com.sg

Building 1, No. 879 Shen Fu Road
XinZhuang Industrial Zone
Min Hang District
Shanghai, China 201108
Tel: 8621 5055 5005
Fax: 8621 5442 5265

marketing.mris@miltonroy.com
www.miltonroy.com.cn

